



**TOWNSHIP OF NORTH HURON
TENDER FOR
CONSTRUCTION OF BLYTH SIGN**

**INFORMATION TO BIDDERS
BMROSS CONTRACT NO. 25267**

1.0 INFORMATION FOR SUBMISSION

1.1 Introduction

The Township of North Huron is requesting tenders for the construction of a new masonry block sign at the south end of Blyth and associated work such as concrete, electrical and site restoration work.

1.2 Date and Place for Receiving Tenders

Tenders will be received by:

**Kevin Watson, Director of Public Works and Facilities
Township of North Huron
274 Josephine Street
Wingham, ON N0G 2W0**

until **2:00:59 p.m. (Local Time), Thursday, April 23, 2026**

The tender submission must include the information listed in the tender submission section. Note, pre-tender site meeting listed in Section 3.1 of this document.

The Township of North Huron reserves the right to accept or reject any or all tenders, and the right to negotiate the scope of work with any Contractor that submits a quote. Lowest price will not necessarily be accepted.

1.3 Withdrawal of Tender

Proponents will be permitted to withdraw their tender, unopened, after it has been deposited, if such a request is received by the Township of North Huron, in writing, prior to the time specified for the opening of tenders.

1.4 General Liability Insurance

The successful proponent must submit a General Liability insurance certificate in the name of the contractor, with the Township of North Huron and B. M. Ross and Associates Limited named as additional insureds, with limits of not less than **five million dollars** inclusive per occurrence for bodily injury, death, and damage to property including loss of use thereof, with a property damage deductible of not more than **\$5,000**. The form of insurance shall be the Insurance Bureau of Canada Form IBC 2100 or equal.

1.5 Workplace Safety and Insurance Board

The successful proponent must be in good standing with the Workplace Safety and Insurance Board and shall submit a current WSIB Clearance Certificate to the Township prior to commencing work.

1.6 Proponent's Responsibility

The successful proponent shall, in all respects, comply with all statutes, laws, and regulations applicable to the work and to persons employed on or in connection with the work, and pay all assessments required or levied by the Workplace Safety and Insurance Board, Revenue Canada, the Employment Insurance and specifically the Ministry of Labour.

1.7 Tender Deposit

The Contractor shall submit a certified cheque, bank draft, or bid bond, for an amount of **\$7,500**, with the tender documents. If a bid bond is submitted, upon award the Contractor shall provide a performance bond for 100% of the bid amount prior to formalizing the contract. If the Contractor chooses to submit a certified cheque in lieu of submitting a bid bond and performance bond, the funds will be held in lieu of a performance bond until the completion of the project.

1.8 Clarification

Any details in question on this tender or in the accompanying plans shall be clarified by the bidder prior to submitting the bid. The prices bid as tendered shall include the supply of all permits, labour, equipment, and materials where they are necessary to complete the contract. For technical questions related to tender documents, please contact:

Ken Logtenberg, Project Manager
B. M. Ross and Associates Limited
Engineers and Planners
Ph: (519) 524-2641
klogtenberg@bmcross.net

Questions shall be provided no later than 5 calendar days before the closing date.

1.9 Payment

Payment will be made as outlined on the tender form. The amounts to be included in interim monthly payment will be based on the amount of work completed, as a percentage of the tender amount and in the opinion of the Contract Administrator (BMROSS).

If there is a dispute amount the amount to be included in interim payments, the OPSS – MUNI 100, General Terms and Conditions for Municipal Project shall apply.

2.0 SCOPE OF WORK

The scope of work for this project shall include the supply of all materials and labour required to complete the following tasks, at the site in Blyth, northwest of County Road 25 and 4 Intersection. The price for the work shall be submitted as itemized within the schedule of items. The work shall be completed as detailed on the tender drawings and shall include as other incidental work required to complete the project.

- Mobilize on site and construct a security fence around the construction area to keep the public out when it is unsafe for the public to enter. The fence must remain in place if there is an open excavation or other hazards exposed to the public, as determined by the Township and Contract Administrator.
- If a building permit is required for this work, the Township will coordinate it and pay the fee associated with a permit.
- Complete all grading, excavation work, backfill and compaction of materials required on the site and perform site restoration at the completion of the work.
- Excavated surplus material that is not suitable for re-use on the site shall be disposed of by the Contractor at an appropriate location that can receive the material.
- Forming and construction of the reinforced concrete footings and foundations wall to support the sign and flag poles.
- Construction of the masonry work as detailed on the drawings or as otherwise approved.
- Relocation of the existing electrical panel and installation of new wiring and flood light to light up the front of the sign. Obtain electrical permits and inspection of the work, if required.
- Restoration of the Blyth Sign, repainting and repairs to the letter on the sign, before installing it on the front of the newly construction masonry sign.
- Installation of three new flag poles on the concrete foundation wall.
- A provisional price shall be provided for an alternative masonry block wall option. Option 1 with 140mm half height but standard masonry block and Option 2 with 90mm standard masonry block and a brick veneer mounted tied to the block wall. See the drawings for the details for the two options.
- Reconstruction of the flower bed area, re-using the existing block retaining wall and salvage or new topsoil to fill the flower bed area in-front of the wall.
- Site clean-up, restoration with topsoil and seeding, disposal of all surplus materials and miscellaneous other site work as shown on contract drawings.

2.1 Materials

All materials supplied by the Contractor shall be as specified and conform with the applicable material specifications.

2.2 Warranty

The Contractor shall rectify any deficiencies or maintenance issues identified within the one year, excluding vandalism or other issues that are not the Contractor's fault. Upon completion, a one year warranty of the installation and the equipment shall be provided by the Contractor to the Owner. A warranty holdback equal to 5% of the tender cost will be withheld until a year after the work is completed.

2.3 Schedule

The schedule assumes the contract will be awarded by early May 2026, and the chosen Contractor will be permitting to proceed with site work any time after award of the work.

The Contractor shall complete all associated work as outlined in this Tender and on the Tender Drawings by: **October 30, 2026**

2.4 Pre-Construction Meeting

Upon award of the contract, and before commencement of the work, the Contractor shall arrange for a pre-construction meeting with the Township and the Contract Administrator.

2.5 Municipal Representatives

The contact for this Request for Tender will be Kevin Watson, Director of Public Works and Facilities, Township of North Huron at P: 519-357-3550 at kwatson@northhuron.ca.

2.6 Drawings

Enclosed Drawing Nos. 1 to 3 were prepared by BMROSS and Associates Limited.

2.7 Applicable Specification

Work shall be completed as per the applicable Ontario Building Code and Ontario Electrical Code, Ontario Provincial Specification listed on the drawings or within the tender documents unless approved otherwise by the Contract Administrator.

3.0 TENDER SUBMISSION AND DOCUMENTS

3.1 General

The submission shall include:

- Signed and completed Form of Tender
- WSIB Clearance Certificate
- Tender deposit or bid bond
- List of sub-contractors, if applicable
- List of references with contract information (minimum of 3)

A pre-tender site meeting will be held on April 16, 2026, commencing at 3:00 p.m. at construction site. Bidder are required to have a representative attend this meeting.

The Township of North Huron reserves the right to accept or reject any or all tenders, and the right to negotiate the scope of work with any Contractor that submits a quote. Lowest price will not necessarily be accepted.

3.2 Tender Documents

Tender documents provided, including Applicable OPSS Specifications and CSA Standards to be reviewed by bidders prior to submission of a tender.

1. Information for Bidders; Parts 1 to 3
2. Form of Tender
3. Drawings 1, 2 and 3

**FORM OF QUOTATION FOR
CONSTRUCTION OF BLYTH SIGN
TOWNSHIP OF NORTH HURON
CONTRACT No. 25267**

A) Scope of Work:

The scope of work for this project shall include the following work within the village of Blyth, at north west corner of Hwy 4 (London Rd) and Blyth Rd.

- Mobilization and providing fencing around work site to satisfy Ministry of Labour.
- Excavation, stockpile on site and backfill around the sign wall.
- Removals and disposal of all surplus materials, earth, concrete, masonry blocks, trees, electrical, etc. Contractor to dispose of all surplus materials in accordance with applicable regulations
- Construction of sign wall with concrete foundations and masonry walls that will have similar features and appears as the sign at the north end of the village.
- Details for Option 1 and 2 for the masonry work are presented on the drawings.
- Supply and place granular A under footing, if required. Provisional item.
- Refurbish existing sign board and mount it on the newly construction wall.
- Install 3 flag poles bearing on concrete foundation wall.
- Relocate topsoil and the block perimeter wall around the existing flower bed.
- Reinstall panel and install wiring and new flood light, as per electrical code.
- Site restoration of all disturbed areas.

Unless stated otherwise, the Contractor shall be responsible for supplying all labour, materials and equipment necessary to complete the work required. The cost to complete all the work required shall be divided into the items listed below.

B) Schedule of Items and Prices:

Item	OPSS Spec. #	Description	Qty./Unit	Price
1	100	Lump sum for mobilization, demobilization and other requirements	1 L.S.	\$ _____
2	706	Fencing and signage placed around work area to Ministry of Labour requirements	1 L.S.	\$ _____
3	510	Removal of existing wall, foundations, trees, light, flag pole, and other surplus materials	1 L.S.	\$ _____
4		Excavation and backfill of the foundation wall	1 L.S.	\$ _____
5	904, 905, 919	Concrete work	1 L.S.	\$ _____
6		Masonry and brick work		
		a) Brick veneer, Option 1	1 L.S.	\$ _____
		b) Masonry 140 half blocks, Option 1	1 L.S.	\$ _____
		c) Concrete caps	1 L.S.	\$ _____
7		Commercial flags poles, 2-16' and 1-20' pole	3 Ea.	\$ _____

Item	OPSS Spec. #	Description	Qty./Unit	Price
8		Salvage and reinstall electrical panel and power supply line, and install new wiring and flood light in front of the sign, where directed.	1 L.S.	\$ _____
9		Refurbish and mount the salvaged "Blyth" sign board.	1 L.S.	\$ _____
10		Using salvaged retaining wall stones and topsoil, create a new flower bed area in front of the sign wall.	1 L.S.	\$ _____
11	802,804	Site clean-up and restoration with topsoil and seed	1 L.S.	\$ _____
12	100	Bonding and insurance	1 L.S.	\$ _____
Provisional Items				
13	314	Granular A under footing	5 tonne	\$ _____
14		Additional cost for brick veneer and masonry block work to satisfy Option 2	1 L.S.	\$ _____
15		Contingency Allowance, only used if there are scope of work increases to the project that are approved by the Owner	1 L.S.	\$ 10,000.00
SUB-TOTAL				\$ _____
13% HST				\$ _____
TOTAL TENDER				\$ _____

C) OPS Specifications and Standard Drawings

- OPSS 100 (General Conditions of Contracts)
- OPSS 314, 706, 802, 804, 904, 905, 919 (Item related specifications)
- OPSD N/A

D) Contract Drawings

BMROSS Project No.25267, Drawing Nos. 1 to 4

E) Terms of Quotation

Completion Date: October 30, 2026
 Maintenance / Lien Holdback: 10% for 60 days
 Warranty holdback of 5% for one year after completion of work.

F) Bonding and insurance

A bid bond or a security deposit must be submitted with a bid. The security deposit may be provide in the form of a certified cheque or bank draft made out to the Township in the amount of \$7,500.

A performance bond for 100% of the tender amount shall be provided or alternatively the tender deposit will be held as a surety until the project is complete.

The Contractor must provide proof of general liability insurance for a minimum amount of \$5,000,000 that lists the Township and BMROSS as additional insured on this project.

The bonding and insurance requirements for this project shall satisfy OPSS 100.

G) Total Quoted Price + HST \$ _____
(insert total tender price from page 2)

_____ hereby certifies that the information given on this Quotation and any documents attached is true, correct and complete in every respect.

Dated at _____, this _____ day of _____, 2026.

Signature of Contractor

Signature of Witness

Company Name

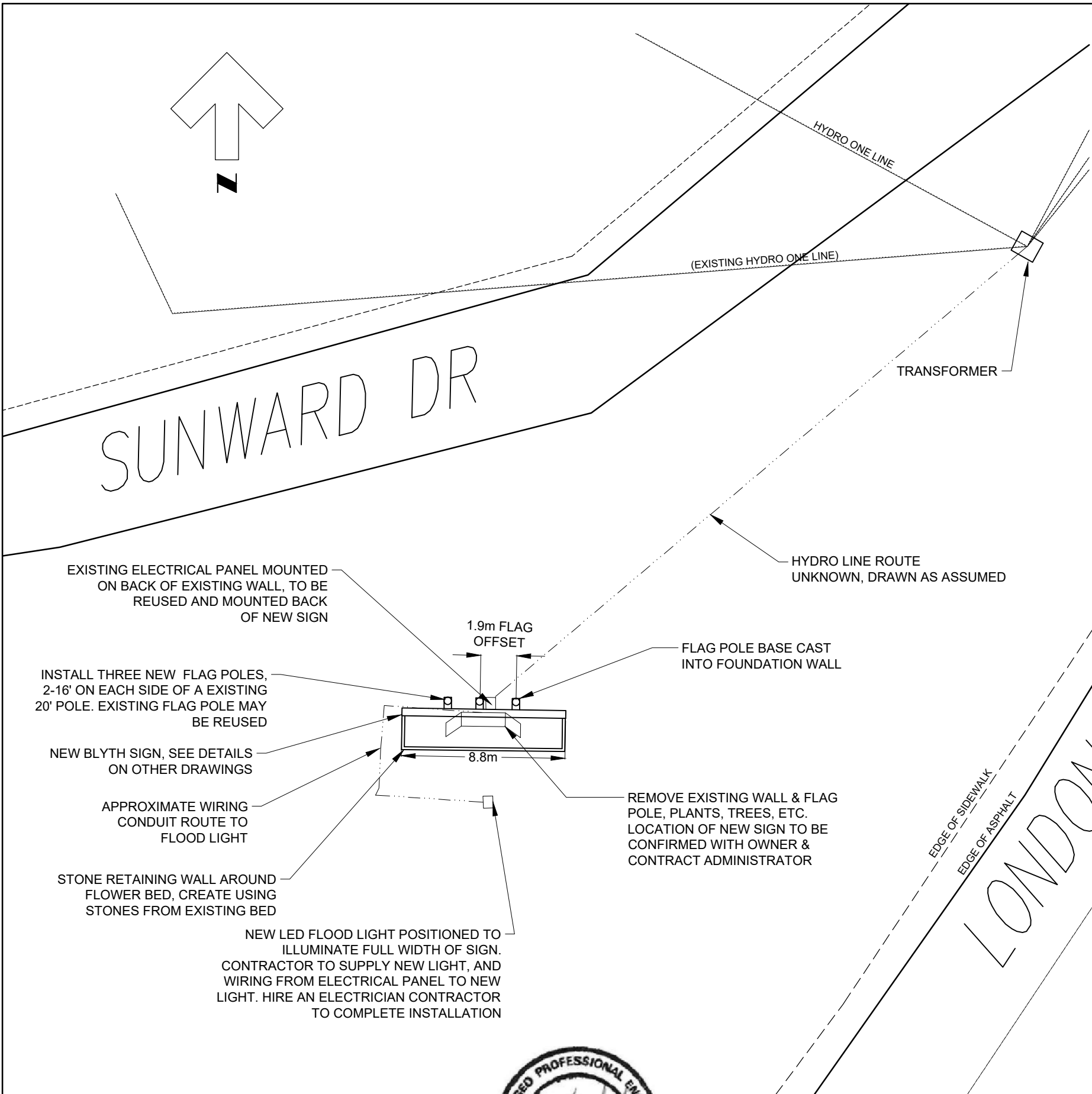
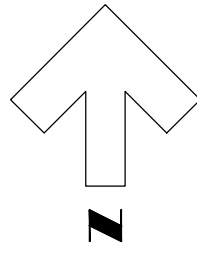

GENERAL NOTES:

1. Contractor to have the locates for the hydro service marked in the field and meet with Municipality and Contract Administrator before starting construction to confirm the location for the sign, trees and shrubs in area to be removed, light locations, etc.
2. Foundation to be backfilled around with salvaged material, compacted in maximum 300mm lifts, with height differential from one side to the other less than 500mm when backfilling the foundation.
3. The existing Blyth plywood sign with the red background shall be salvaged for re-use. Prior to placing, the sign shall be touched up with a new coat of paint, replace broken letters and remount sign after restoring, and installed with a new aluminum angled frame placed against bricks to support the sign.
4. Electrical work to be completed in accordance with the Electrical Code by a licensed electrician.
5. Disturbed area on the site are to be restored with topsoil and grass seed, MTO roadside mix, placed as per OPSS 802 and 804. Contractor shall water grass seeded area regularly until a uniform catch of grass is established.
6. If the Contractor leaves site before the work is completed, while waiting for another sub-contractor to complete their work, the fencing around the work area must either remain in place or the site must be returned to a safe state, to the satisfaction of the Municipality and Contract Administrator, with no open excavation or exposed rebar protruding out of the concrete foundations.
7. Flag poles shall be made of extruded aluminum tubing, tapered over the length, constructed of 6036-T6 material, designed to resist local wind speeds with external hardware to mount the flags. Shop drawings of proposed flag poles to be supplied for approval by Contract Administrator before ordering. Poles to be installed as per the supplier specifications and anchored into the concrete with stainless bolts.

EXISTING ELECTRICAL PANEL MOUNTED ON BACK OF EXISTING WALL, TO BE REUSED AND MOUNTED BACK OF NEW SIGN

INSTALL THREE NEW FLAG POLES, 2-16' ON EACH SIDE OF A EXISTING 20' POLE. EXISTING FLAG POLE MAY BE REUSED

NEW BLYTH SIGN, SEE DETAILS ON OTHER DRAWINGS

APPROXIMATE WIRING CONDUIT ROUTE TO FLOOD LIGHT

STONE RETAINING WALL AROUND FLOWER BED, CREATE USING STONES FROM EXISTING BED

NEW LED FLOOD LIGHT POSITIONED TO ILLUMINATE FULL WIDTH OF SIGN. CONTRACTOR TO SUPPLY NEW LIGHT, AND WIRING FROM ELECTRICAL PANEL TO NEW LIGHT. HIRE AN ELECTRICIAN CONTRACTOR TO COMPLETE INSTALLATION

1.9m FLAG OFFSET

8.8m

FLAG POLE BASE CAST INTO FOUNDATION WALL

REMOVE EXISTING WALL & FLAG POLE, PLANTS, TREES, ETC. LOCATION OF NEW SIGN TO BE CONFIRMED WITH OWNER & CONTRACT ADMINISTRATOR

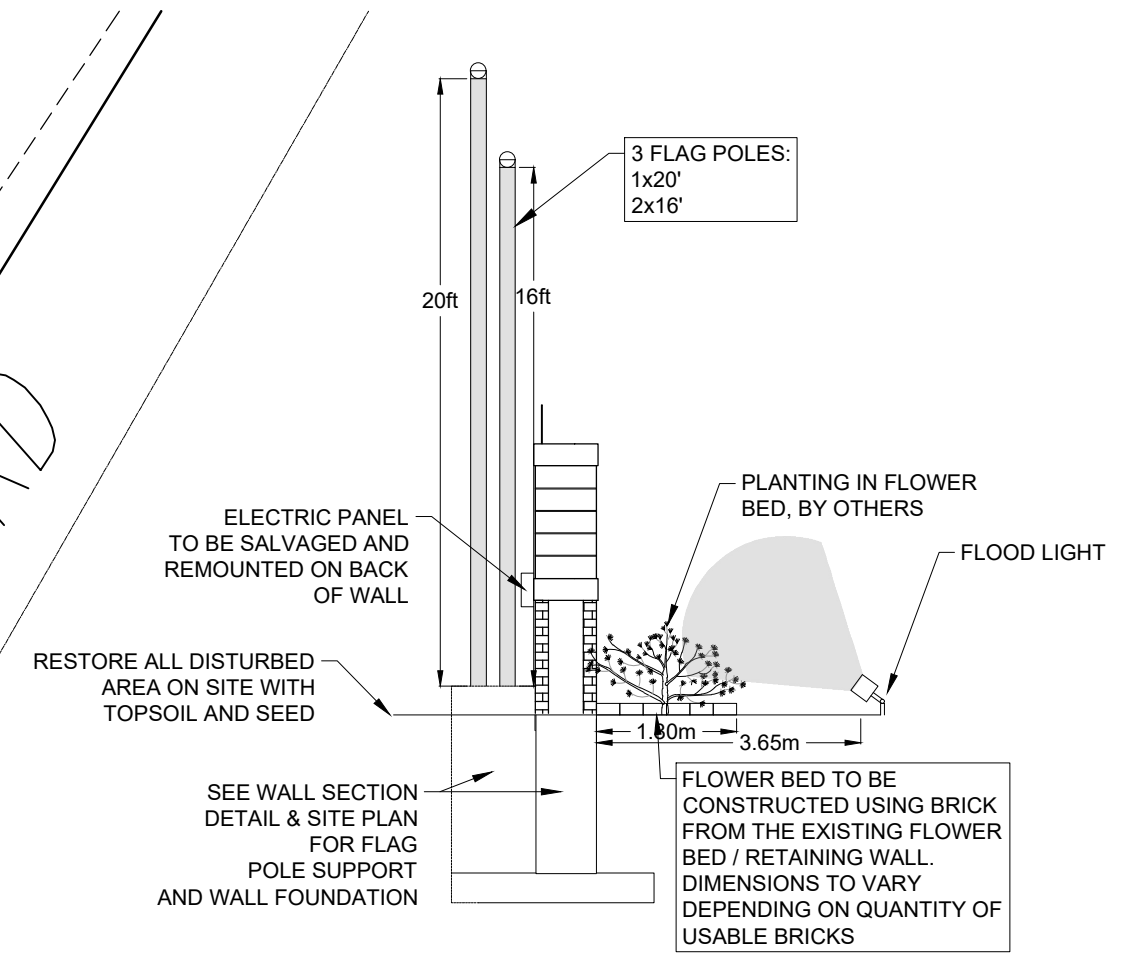

SITE CROSS-SECTION
SCALE: 1 TO 100

SITE PLAN
SCALE: 1 TO 250



No.	DATE	REVISION
--	2026/03/27	OUT FOR TENDER



Goderich Kincardine Mount Forest Sarnia

Township of North Huron
CONSTRUCTION OF BLYTH SIGN
SITE PLAN

CONTRACT No. 1	PROJECT No. 25267
SCALE 1 TO 250	DRAWING No. 1 OF 3

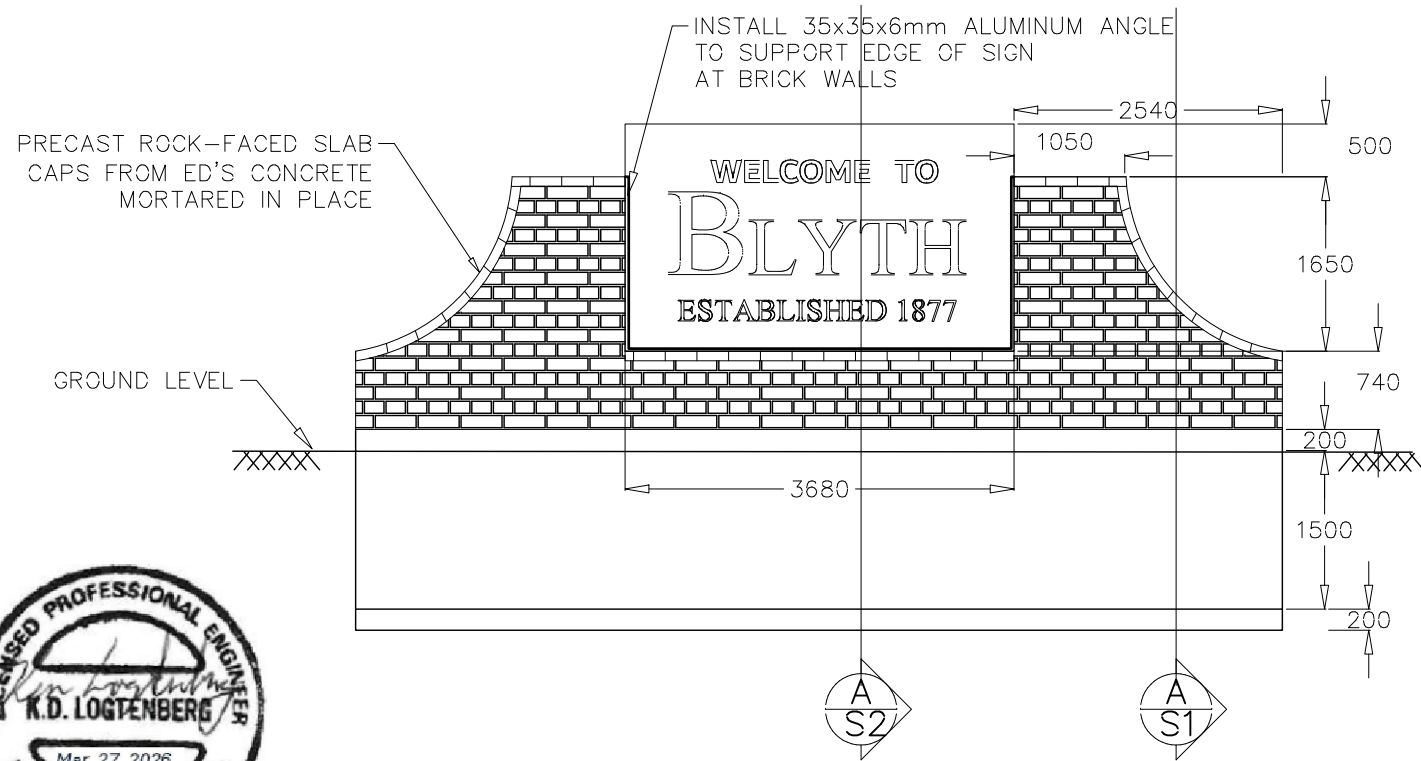

SIGN ELEVATION

SCALE: 1 TO 75

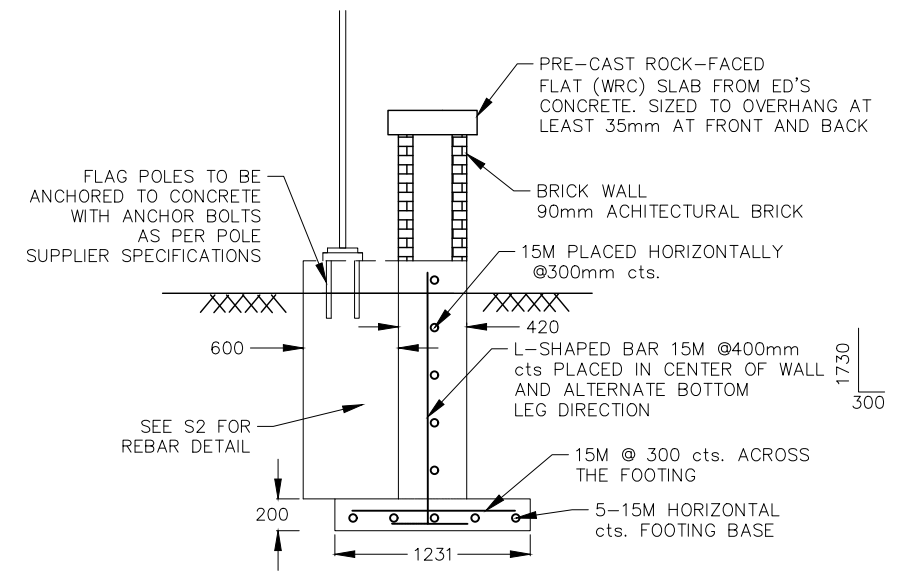

WALL SECTION S1

SCALE: 1 TO 50

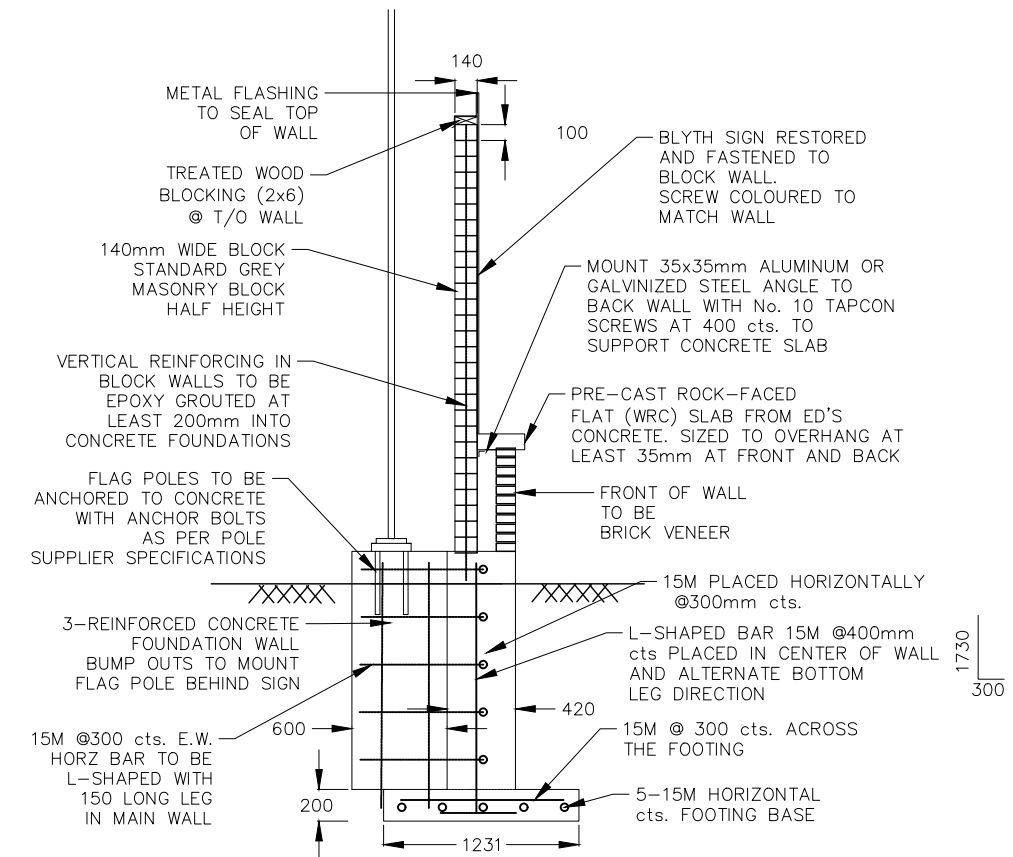

WALL SECTION S2 (SHOWING OPTION 1)

SCALE: 1 TO 50



MASONRY NOTES:

- Masonry blocks units, associated accessories and placement methods shall comply with CSA standards. Namely in accordance with CSA A165 for concrete masonry units, CSA A371 for methods of construction, CSA A370 for connectors, CSA A179 for mortar and grouts for unit masonry.
- Horizontal wall reinforcement shall be Dur O Wal Ltd. truss or ladder type or approved equal, with minimum 3.66 mm (9 gauge) galvanized wire, and shall conform to CSA Standard G30.3. Horizontal reinforcing shall be placed in block and brick and shall be placed at 400mm cts vertically.
- Masonry blocks shall be structural cement blocks, minimum 15 MPa units, mortar for blocks shall be Type S Mortar with a minimum strength of 12.5 MPa. Grout shall have a maximum coarse aggregate size of 10mm and minimum strength of 12.5 MPa.
- Reinforcing steel in masonry shall conform with CSA G30.18, Grade 400R, deformed bars. Bars may be cut and bent to suit at the site.
- The veneer bricks shall be from Shouldice Stone, textured Apex Stone in colour polar. The bricks shall be about 2.25" high and have varying length with about 10% of the bricks 24" long, 20% about 16" long, 30% about 12" long and about 40% 8" long. When placing the bricks, different lengths shall be distributed through the wall face. Mortar for brick veneer shall be Type N, (minimum strength 8 Mpa) with colour similar to sign at the north end of town. Contractor to provide sample of bricks, blocks and coloured mortar for owner to approve prior to ordering. At that time, a decision between Option 1 or 2 for the rear wall will be decided.
- Lay-up masonry in running bond, unless approved otherwise. Where masonry is exposed the contractor shall provide smooth and uniform concave mortar joints.
- Work shall not take place when temperatures are below 5 degrees celsius unless approved by the Contract Administrator.
- Brick ties shall be placed at maximum 800mm cts horizontally at 400mm cts vertically. Colour matching weeper vents are to be installed at base @ 800 cts.

CONCRETE NOTES:

- Concrete for foundations shall be CSA exposure class F1 (30MPa) or C2 (32MPa). Concrete shall have 5 to 7% air entrainment with 19mm course aggregates.
- Reinforcing steel shall be new deformed bars grade 400. Bars may be cut and bent on site.
- Cover to reinforcing steel 70mm ± 20 except where noted.
- Lap splice information (unless noted otherwise)
15M - 480mm; 10M - 380mm
- Exposed concrete shall have uniform smooth finish and if it has a rough surface, the surface shall be refaced with a cement paste within 2 days after forms are removed.
- Excavate and cast footing on native undisturbed material, unless directed otherwise. If unable to provide smooth native surface for footing, or additional material has to be removed below specified footing depth, place compacted granular A under footings. Soil bearing capacity of 125 kPa has been assumed.
- Concrete footings shall not be placed until excavation, formwork/falsework, and reinforcing steel have been reviewed by the Building Official or the Design Engineer.
- The concrete, reinforcing steel and formwork shall be placed in conformance with OPSS 904, 905 and 919, respectively for concrete structures.

No.	DATE	REVISION
--	2026/03/27	OUT FOR TENDER



Goderich Kincardine Mount Forest Sarnia

Township of North Huron
CONSTRUCTION OF BLYTH SIGN
 ELEVATION VIEW AND SECTIONS

CONTRACT No.	PROJECT No.
1	25267
SCALE	DRAWING No.
AS NOTED	2 OF 3

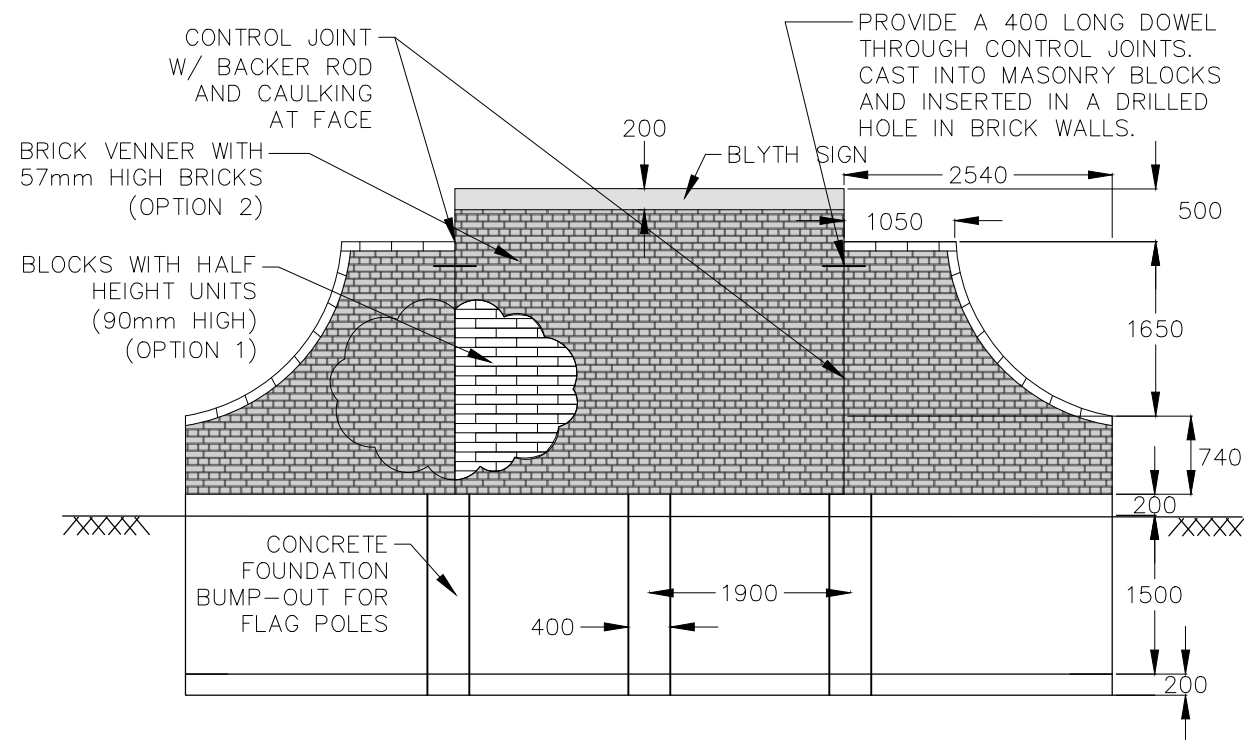

**REAR OF SIGN
ELEVATION VIEW**
SCALE: 1 TO 75

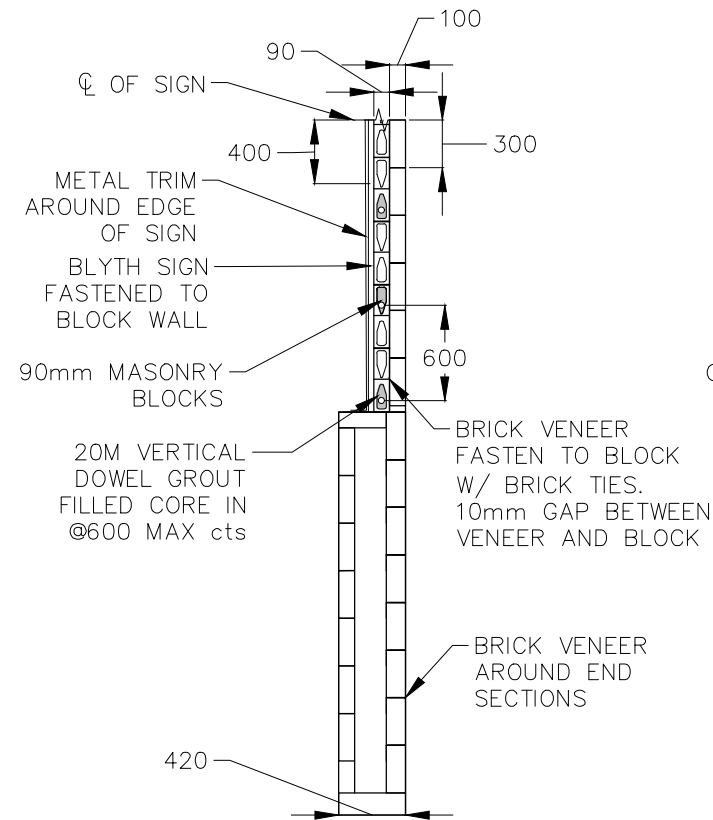

**BRICK OPTION 2
VENEER & BLOCK
PLAN VIEW**
SCALE: 1 TO 50

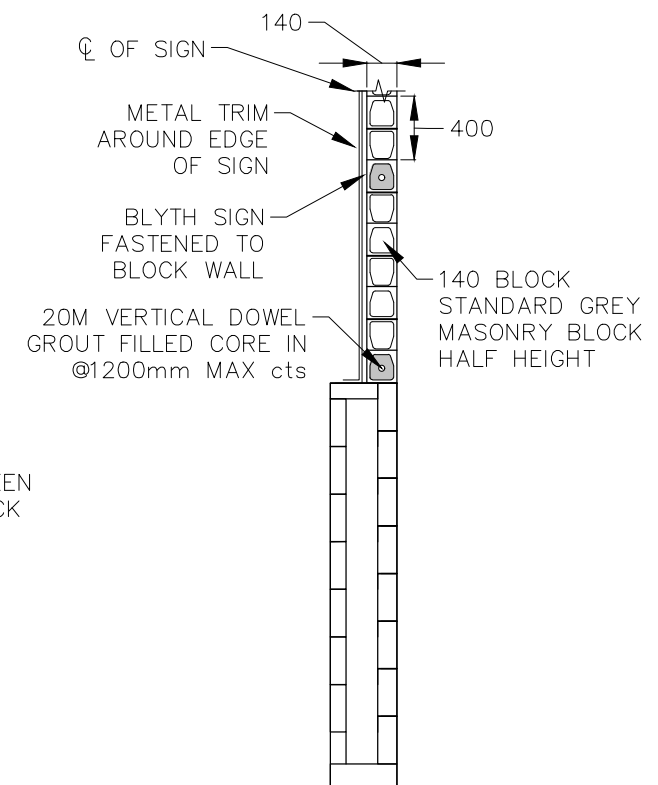

**BRICK OPTION 1
BLOCK ONLY
PLAN VIEW**
SCALE: 1 TO 50



No.	DATE	REVISION
--	2026/03/27	OUT FOR TENDER



Goderich Kincardine Mount Forest Sarnia

Township of North Huron
CONSTRUCTION OF BLYTH SIGN
ELEVATION VIEW AND
HORIZONTAL SECTIONS

CONTRACT No.	PROJECT No.
1	25267
SCALE	DRAWING No.
SEE SCALE	3 OF 3